

AGET

CAPTURE IT. FILTER IT. BREATHE IT.®

DUSTKOP Downdraft Tables



Shown above: Model DDT-3630

A high efficiency solution for your dust collection requirement

AGET downdraft tables are engineered to protect manufacturing environments and collect dust and fumes created from multiple handheld fabricating processes. When attached to an exhauster powered dust collector, the downdraft table design captures contaminants to be drawn into the collection system and away from the worker's breathing zone.

Downdraft tables provide an effective dust containment method for cutting, grinding, polishing and buffing. The modular design allows multiple down-draft tables to be placed together in a work area and connected to a single pull-through dust collector.

AGET downdraft tables are an efficient, economical way to help comply with OSHA Clean Air Standards and to protect employees from hazardous dust, smoke, and fumes generated by various industrial processes.

STANDARD FEATURES

- Heavy-duty, all steel welded industrial grade construction
- Hopper style bottom to exhaust outlet
- Industrial grade open steel grating work surface
- Powder coated, durable, long-lasting finish
- Stand-alone, simple design allows for connection to existing dust collector, reducing the need for additional power consuming equipment

Standard workspace sizes: range from 36" x 30" to 48" x 96"

Capacity range: 150 – 250 CFM per square foot
(job specific requirement)

Common applications: metalworking and woodworking processes:
cutting, grinding, buffing, polishing, etc.

OPTIONAL FEATURES

- PVC open mesh surface matting to protect delicate or finished parts
- Back and side shields to eliminate cross-drafts and contain debris (standard height 18")
- Booth enclosures and lighting for optimal workplace visibility
- Optional white interior finish on booth to enhance illumination
- Cleanout door in standard outlet elbows for easy access to retrieve parts or tools
- Exhaust manifold for single point duct connection
- Special paint (special color, 2-part epoxy, USDA White, etc.)
- Stainless steel construction
- Job specific sizing and modifications



DUSTKOP Downdraft Tables

Standard Specifications

Model	Hopper Style	Outlet Elbow	Estimated Shipping Weight	Dimensions			
				A	B	C	D
DDT-3630	1	7", 8"	330 lbs.	36"	30"	38"	56"
DDT-3636	1	7, 8, 9"	360 lbs.	36"	36"	38"	56"
DDT-3642	1	8", 10"	370 lbs.	36"	42"	38"	56"
DDT-4836	1	9", 10"	380 lbs.	48"	36"	38"	56"
DDT-4842	1	10", 12"	410 lbs.	48"	42"	38"	56"
DDT-4848	1	10", 12"	430 lbs.	48"	48"	38"	56"
DDT-3660	2	two 7" or 8"	660 lbs.	60"	36"	38"	56"
DDT-3672	2	two 7", 8" or 9"	700 lbs.	72"	36"	38"	56"
DDT-3684	2	two 8" or 10"	750 lbs.	84"	36"	38"	56"
DDT-4872	2	two 9" or 10"	750 lbs.	72"	48"	38"	56"
DDT-4884	2	two 10" or 12"	800 lbs.	84"	48"	38"	56"
DDT-4896	2	two 10" or 12"	865 lbs.	96"	48"	38"	56"

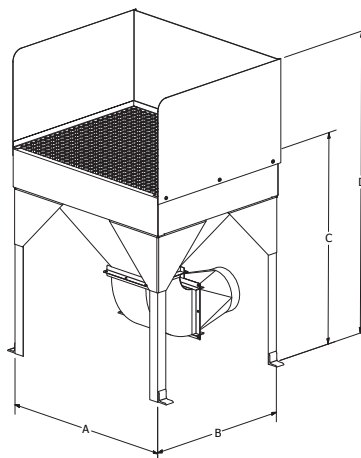

Shown at right: Model DDT-3672 with optional PVC open mesh surface matting, manifold option to single exhaust outlet, and booth enclosure with lighting.



Contact AGET Manufacturing or your local AGET representative today for additional information and factory replacement parts.

Made in the U.S.A.

AGET Manufacturing Company 1408 E. Church Street, Adrian, MI 49221-3437
 Phone: (800) 832-2438 Fax: (517) 263-7154 sales@agetmfg.com www.agetmfg.com



DUSTKOP
STOPS DUST